

# DECISION/DIRECTION NOTE

---

<b>Title:</b>	Installation of Awnings 16 Queen Street, Cornerstone Theatre
<b>Date Prepared:</b>	July 17, 2018
<b>Report To:</b>	Committee of the Whole
<b>Councillor &amp; Role:</b>	Councillor Maggie Burton, Planning and Development Lead
<b>Ward:</b>	2

---

**Decision/Direction Required:** To seek approval for the installation of five (5) awnings above ground floor windows and one (1) awning sign, located at 16 Queen Street (Cornerstone Theatre).

**Discussion – Background and Current Status:**

The City has received an application for the installation of awnings above the ground floor windows of the Cornerstone Theatre (currently the Cotton Club), located at 16 Queen Street. The application also includes the replacement of an awning sign located above the door of the George Street entrance. A previous application was reviewed by the Built Heritage Experts Panel on July 12<sup>th</sup>, 2018, however the application has been updated to include the addition of an awning sign.

The subject property is located within Heritage Area 2, the Commercial Downtown (CD) District of the St. John's Municipal Plan and is zoned Commercial Central Mixed (CCM). The building is designated by Council as a Heritage Building and therefore any repairs must seek approval from Council.

From Regulation 5.9.4 Heritage Area Standards (Table), fabric canopies and awnings on non-residential properties may be permitted where, in the opinion of the Inspector, the design, construction and materials used are compatible with the period streetscape. In 2001, the Heritage Foundation of Newfoundland and Labrador prepared a document entitled *Working with Heritage: Downtown St. John's Commercial Properties, Signage, Awnings and Storefronts*. This document states that fabric awnings are the most historically appropriate type of awning for downtown St. John's. At ground level, the awnings should match the width of the window opening and while the color choice remains with the owner, it is recommended that awnings reinforce the façade and sign colour scheme and may be a single colour or feature a two-colour stripe. However, the document notes that at ground level awnings should avoid placement that obscures details of the façade. The document also states that curved canopy style signage does not fit with the look of restored buildings.

The applicant has proposed a total of five window awnings and one awning sign. A rendering of the awnings is attached for your reference. The awnings will be non-illuminated exterior awnings with an aluminum skeleton. The fabric skin will be the 20oz Cooley Brite II Awning, which is made of polyester with a PVC coating. The color is proposed to be solid black, which matches the sign awning above the main door. The awning sign above the door will have a vinyl Cornerstone Sports Bar logo.

- The current awning sign on George Street is a curved canopy awning. The proposed awning sign is a more traditional awning that is more in keeping with historic awnings. As the application is for

---

# ST. JOHN'S

replacement of an existing sign, and the proposed sign is more in keeping with the standards, the awning sign is recommended for approval.

- With respect to the window awnings, two will be above ground floor windows facing Queen Street and three will be above ground floor windows facing George Street. The window awnings facing Queen Street are a replacement of awnings that have been damaged. While the proposed awnings are typical of the historic downtown commercial area, given that the building is a designated heritage building it is recommended to refuse the application for five ground-floor window awnings as they would obscure architectural details of the building.

**Key Considerations/Implications:**

1. Budget/Financial Implications: Not applicable.
2. Partners or Other Stakeholders: Not applicable.
3. Alignment with Strategic Directions/Adopted Plans:  
*Neighbourhoods Build our City* – Maintain and position downtown as a distinct neighbourhood.
4. Legal or Policy Implications: Not applicable.
5. Engagement and Communications Considerations: Not applicable.
6. Human Resource Implications: Not applicable.
7. Procurement Implications: Not applicable.
8. Information Technology Implications: Not applicable.
9. Other Implications: Not applicable.

**Recommendation:**

It is recommended to approve the replacement of an awning sign facing George Street, located at 16 Queen Street. It is further recommended to refuse the application for five ground-floor window awnings as they would obscure architectural details around the windows.

**Prepared by/Signature:**

Ann-Marie Cashin, MCIP – Planner III, Urban Design and Heritage

Signature:  \_\_\_\_\_

**Approved by/Date/Signature:**

Ken O'Brien, MCIP – Chief Municipal Planner

Signature:  \_\_\_\_\_

AMC/dlm



**Attachments:**  
Location of Subject Property  
Applicant's Submission

G:\Planning and Development\Planning\2018\Built Heritage Experts Panel\BHEP - 16 Queen Street Revised - July 17 2018 - revised.docx

**Location of Subject Property**  
16 Queen Street







ER SHOWS  
LITTLE ENTERTAINMENT  
\$7 DRINKS  
1 HOUR & 15 EVERY NIGHT  
Cotton Club

XXX  
Cotton Club  
COLUMBIA'S PREMIERE EXOTIC CLUB

NO LEFT TURN  
EXCEPT BY PERMIT  
10:00 AM - 4:00 PM

EXISTING CONDITION 2018-08-03 KP





# The CornerStone Building

Erected in 1861

- |                           |                             |
|---------------------------|-----------------------------|
| 1862 Fisheries Hall       | 1903 Frank MacNamara Ltd.   |
| 1872 St. Peter's Church   | 1967 JB Hann & Sons Ltd.    |
| 1875 Sisters of Mercy     | 1985 Cornerstone Sports Bar |
| Catholic School for Girls | 2001 The Cotton Club        |

NO PARKING  
HERE TO  
CORNER

THE  
SK  
We C





**THE CORNER STONE**  
Sports Lounge

**THE CORNER STONE**  
Sports Lounge

WE GOT YOUR GAME.  
[www.cornerstonelounge.com](http://www.cornerstonelounge.com)

OPEN 2PM EVERY DAY

THE CORNER STONE  
NO SMOKING  
PLEASE REFRAIN FROM DRINKING AND DRUGS  
NO ALCOHOL BEVERAGES AT ENTRANCE

OPEN

JUG 852



NON-ILLUMINATED EXTERIOR AWNINGS CONSTRUCTED OF A WELDED 1" X 1" X 1/8" ALUMINUM TUBING SKELETON COMPLETE WITH BLACK COOLEY FABRIC SKIN. METRO SIGNS TO MANUFACTURE AND SUPPLY ONLY, INSTALL BY OTHERS. (5 REQUIRED TOTAL)

FRONT VIEW

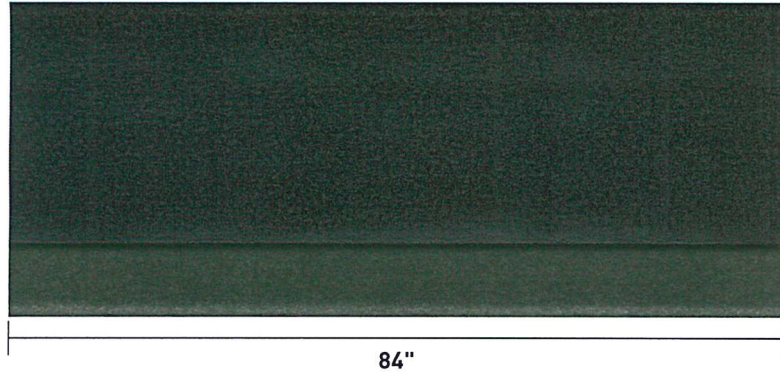

END VIEW

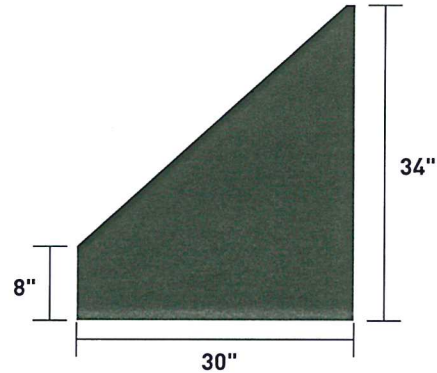

ISOMETRIC VIEW

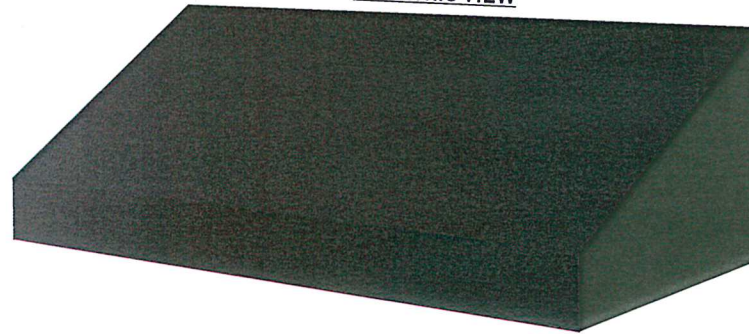

ISOMETRIC VIEW OF 1/8" Z-BRACKETS

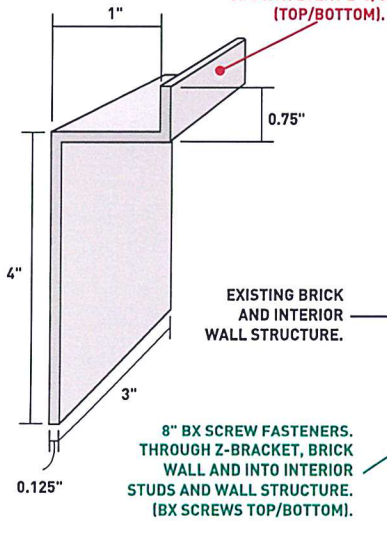

1/8" Z-BRACKET APPROX EVERY 2' o/c (TOP/BOTTOM).

EXISTING BRICK AND INTERIOR WALL STRUCTURE.

8" BX SCREW FASTENERS. THROUGH Z-BRACKET, BRICK WALL AND INTO INTERIOR STUDS AND WALL STRUCTURE. (BX SCREWS TOP/BOTTOM).

FABRIC AWNING CONSTRUCTED OF 1" X 1" X 1/8" ALUMINUM TUBING.



20oz. COOLEY BRITE II AWNING FABRIC IN BLACK OR COMPARABLE MATERIAL.

CUSTOMER:

The Cotton Club

ADDRESS:

N/A

DATE:

May 10th, 2018

NOTES:

CUSTOMER APPROVAL:

PLEASE SIGN AND DATE

DRAWING: Exterior Awnings.ai

FILE: Cotton Club -> 11160

The content of this drawing is the copyrighted property of Metro Signs Inc. and must not be used, duplicated, or altered without the direct consent of the above mentioned. Metro Signs Inc. 2017©



Metro Signs Inc.  
sales@metrosigns.tv  
709.757.4636

NON-ILLUMINATED EXTERIOR AWNINGS CONSTRUCTED OF A WELDED 1" X 1" X 1/8"  
 ALUMINUM TUBING SKELETON COMPLETE WITH BLACK COOLEY FABRIC SKIN WITH VINYL GRAPHICS.  
 METRO SIGNS TO MANUFACTURE AND SUPPLY ONLY, INSTALL BY OTHERS.  
 (1 REQUIRED TOTAL)

FRONT VIEW

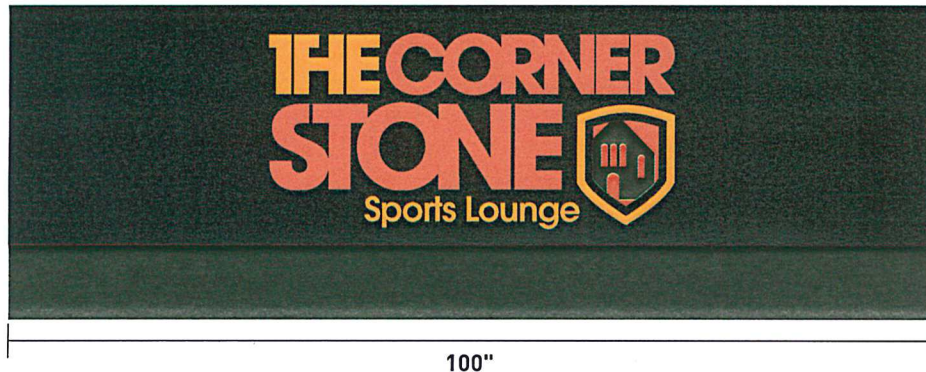

END VIEW

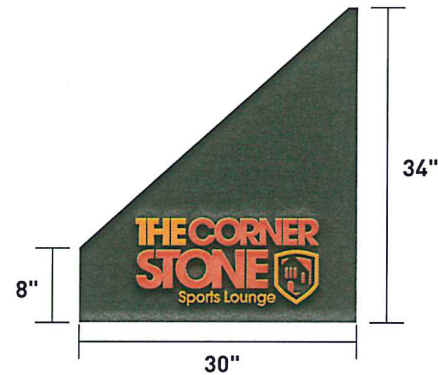

ISOMETRIC VIEW



ISOMETRIC VIEW OF 1/8" Z-BRACKETS

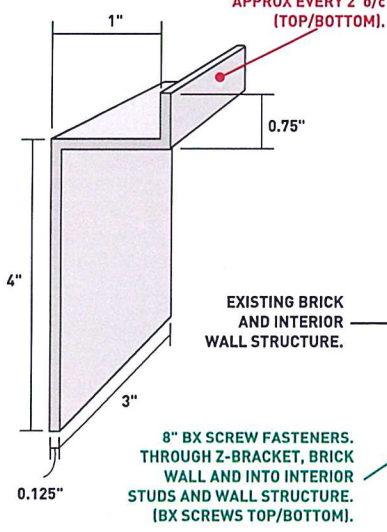

1/8" Z-BRACKET  
 APPROX EVERY 2' o/c  
 (TOP/BOTTOM).

EXISTING BRICK  
 AND INTERIOR  
 WALL STRUCTURE.

FABRIC AWNING  
 CONSTRUCTED  
 OF 1" X 1" X 1/8"  
 ALUMINUM TUBING.

8" BX SCREW FASTENERS.  
 THROUGH Z-BRACKET, BRICK  
 WALL AND INTO INTERIOR  
 STUDS AND WALL STRUCTURE.  
 (BX SCREWS TOP/BOTTOM).



20oz. COOLEY BRITE II AWNING  
 FABRIC IN BLACK OR COMPARABLE  
 MATERIAL.

**CUSTOMER:**  
 The Cotton Club

**ADDRESS:**  
 N/A

**DATE:**  
 May 10th, 2018

**NOTES:**

---

**CUSTOMER APPROVAL:**

PLEASE SIGN AND DATE

**DRAWING:** Exterior Awnings.ai

**FILE:** Cotton Club -> 11160

The content of this drawing is the copyrighted property of Metro Signs Inc. and must not be used, duplicated, or altered without the direct consent of the above mentioned.  
 Metro Signs Inc. 2017©

**metro SIGNS** inc.

Metro Signs Inc.  
 sales@metrosigns.tv  
 709.757.4636





LOCATION OF EXISTING SECURITY CAMERAS. CAMERAS MAY HAVE TO BE MOVED TO ANOTHER LOCATION AS IT IMPEDES INSTALLATION. INSTALL BY OTHERS.



LOCATION OF EXISTING SECURITY CAMERA. CAMERA MAY HAVE TO BE MOVED TO ANOTHER LOCATION AS IT IMPEDES INSTALLATION. INSTALL BY OTHERS.

**CUSTOMER:**

The Cotton Club

**ADDRESS:**

N/A

**DATE:**

May 10th, 2018

**NOTES:**

**CUSTOMER APPROVAL:**

-----  
PLEASE SIGN AND DATE

**DRAWING:** Exterior Awnings.ai

**FILE:** Cotton Club → 11160

The content of this drawing is the copyrighted property of Metro Signs Inc. and must not be used, duplicated, or altered without the direct consent of the above mentioned.  
Metro Signs Inc. 2017©



Metro Signs Inc.  
sales@metrosigns.tv  
709.757.4636